



The Cerebellum and Overall Motor Control

Faisal I. Mohammed, MD, PhD

[Objectives]

- 👁 Describe cerebellar afferents and efferents
- 👁 Outline the functional unit of the cerebellum (circuit)
- 👁 Explain how this unit perform the cerebellar functions
- 👁 Recognize cerebellar abnormalities

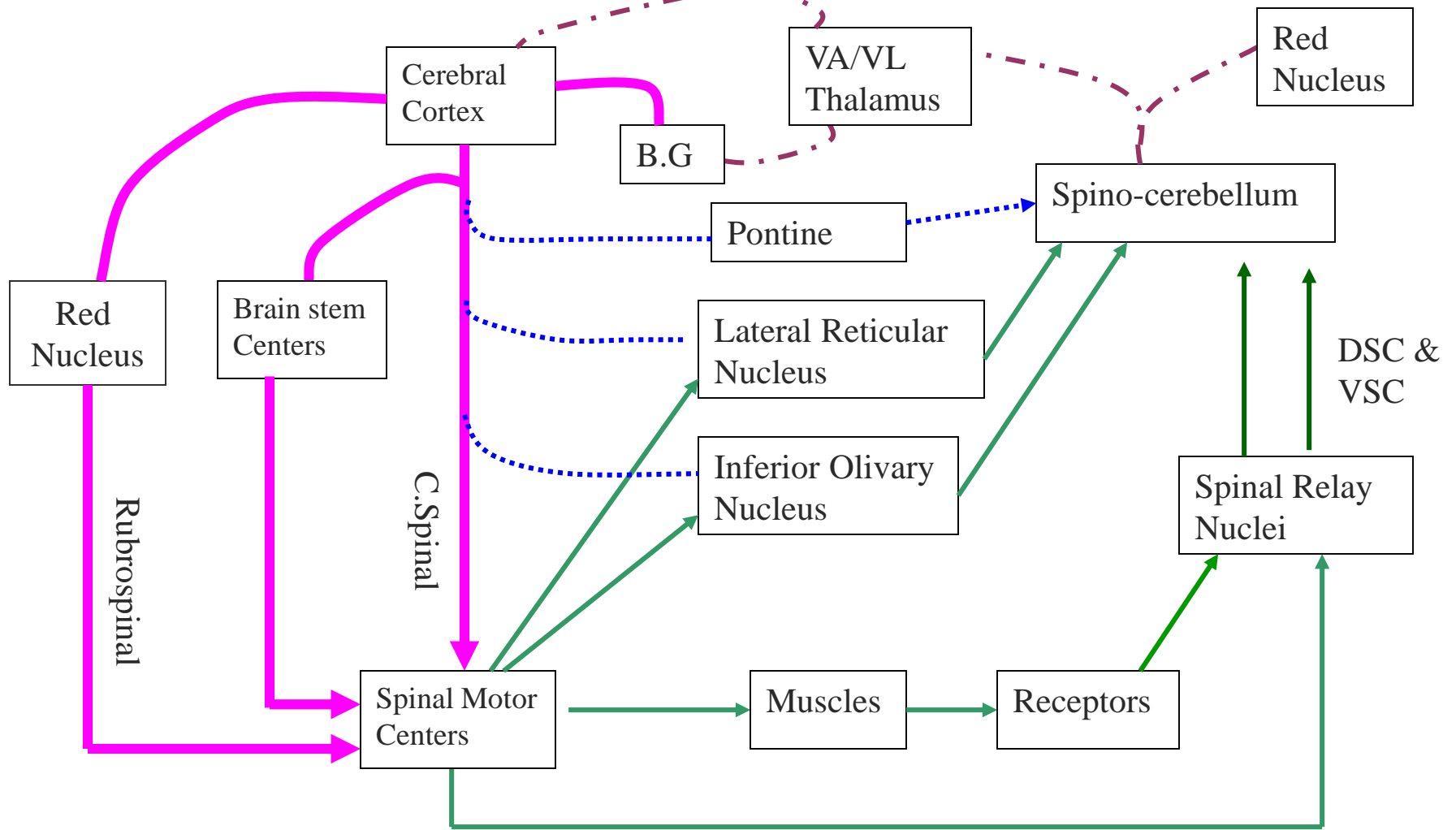

-  Motor Command
-  Feed Back
-  Command Monitor
-  Corrective Command

Motor System

The Cerebellum (little brain)

- responsible for coordinating muscle activity
- sequences the motor activities
- monitors and makes corrective adjustments in the activities initiated by other parts of the brain
- compares the actual motor movements with the intended movements and makes corrective changes

The Cerebellum

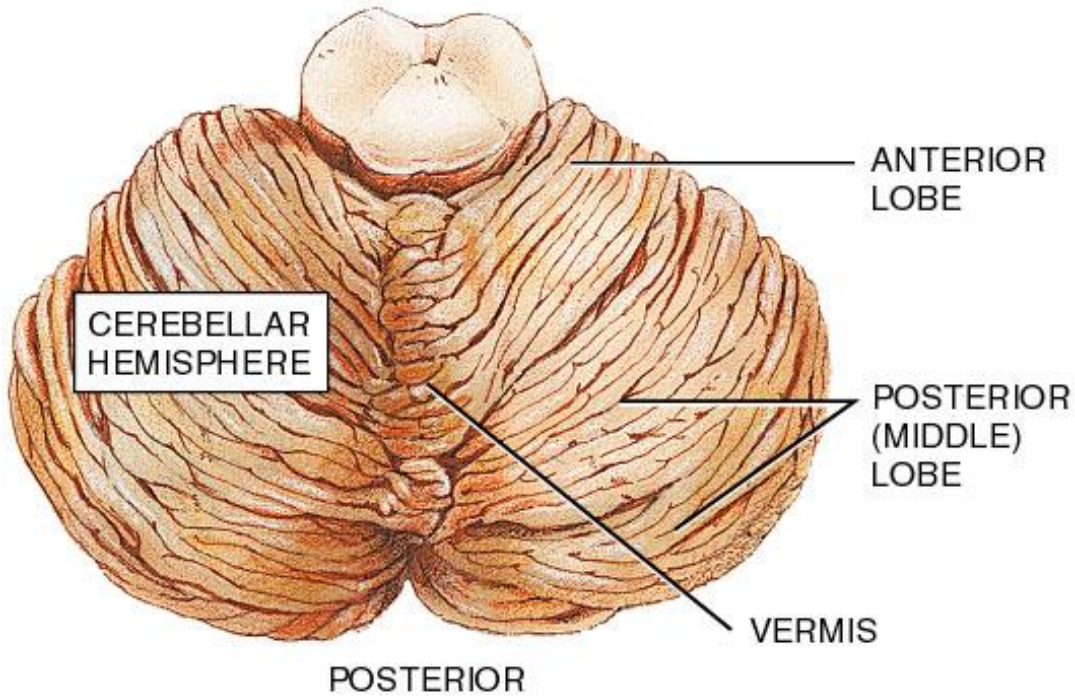
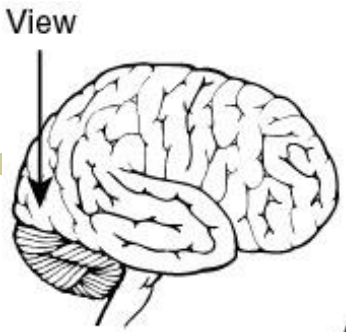

(a) Superior view

The Cerebellum

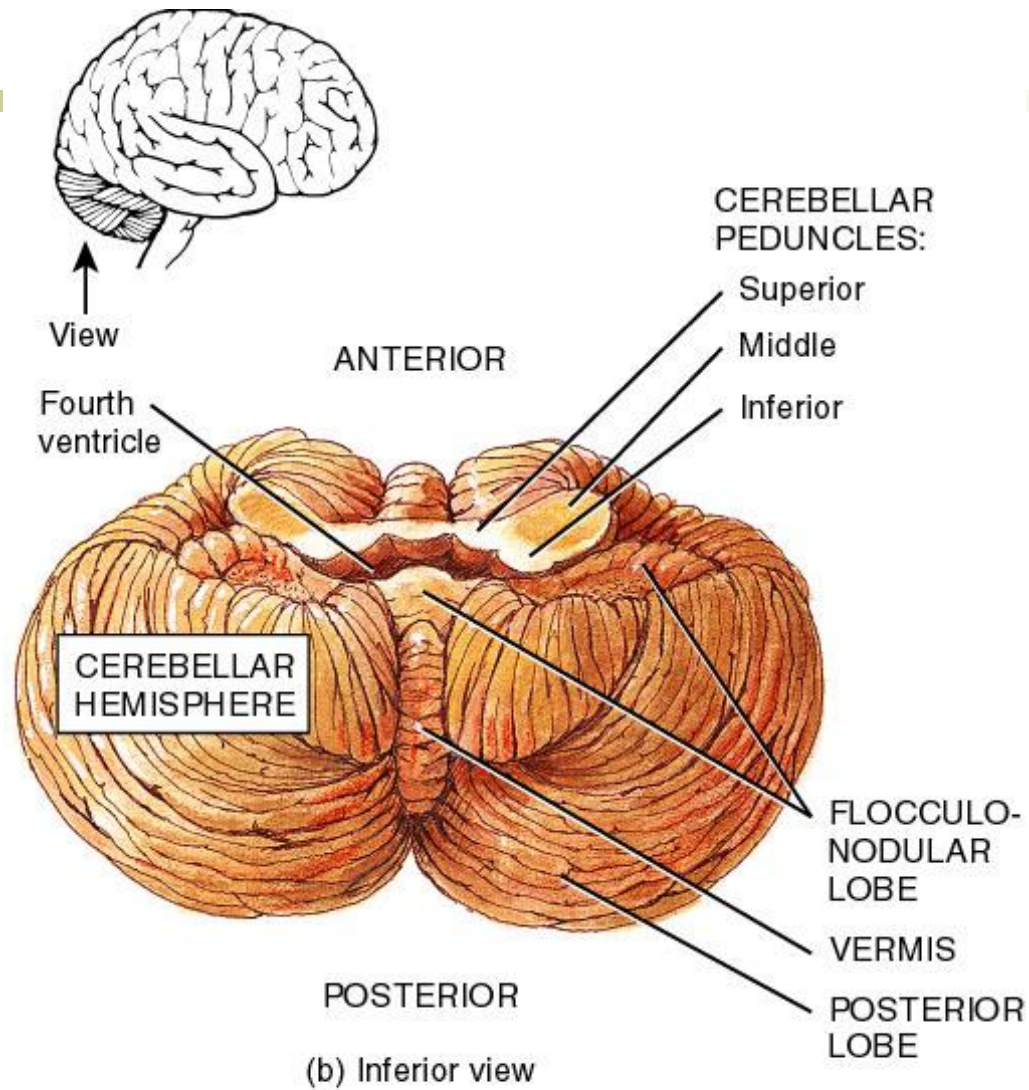

The Cerebellum

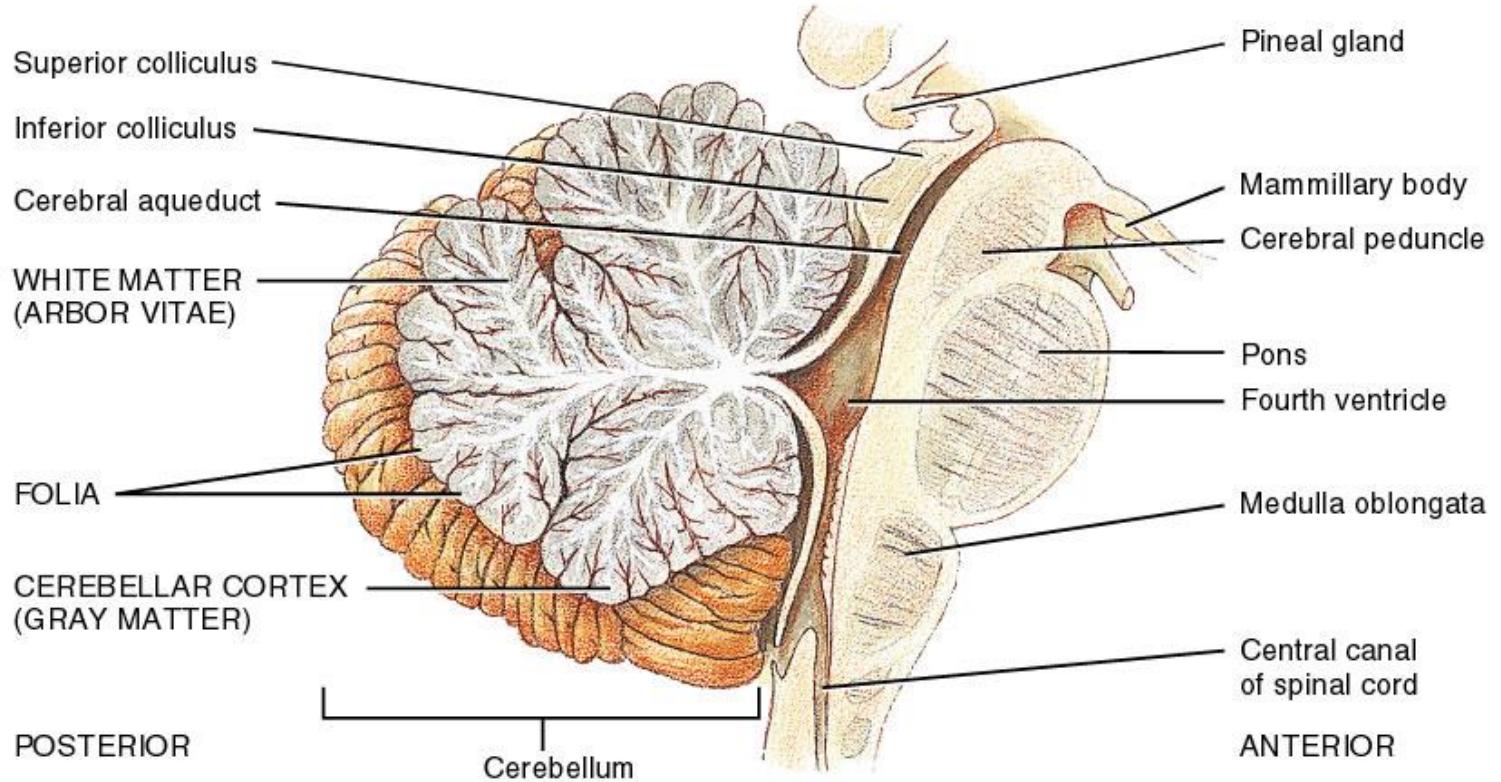
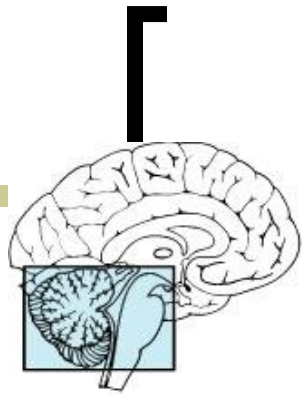

(c) Midsagittal section of cerebellum and brain stem

14.08c

Functional Organization of the Cerebellum

- Functionally arranged along the longitudinal axis
- *Vermis*, located at the center, controls axial movements of the neck, shoulders, and hips
- *Intermediate zone* controls motion of distal portions of upper and lower limbs especially the hands and feet
- *Lateral zone* controls sequencing movements of the muscle. Important for **timing** and **coordination** of movement.

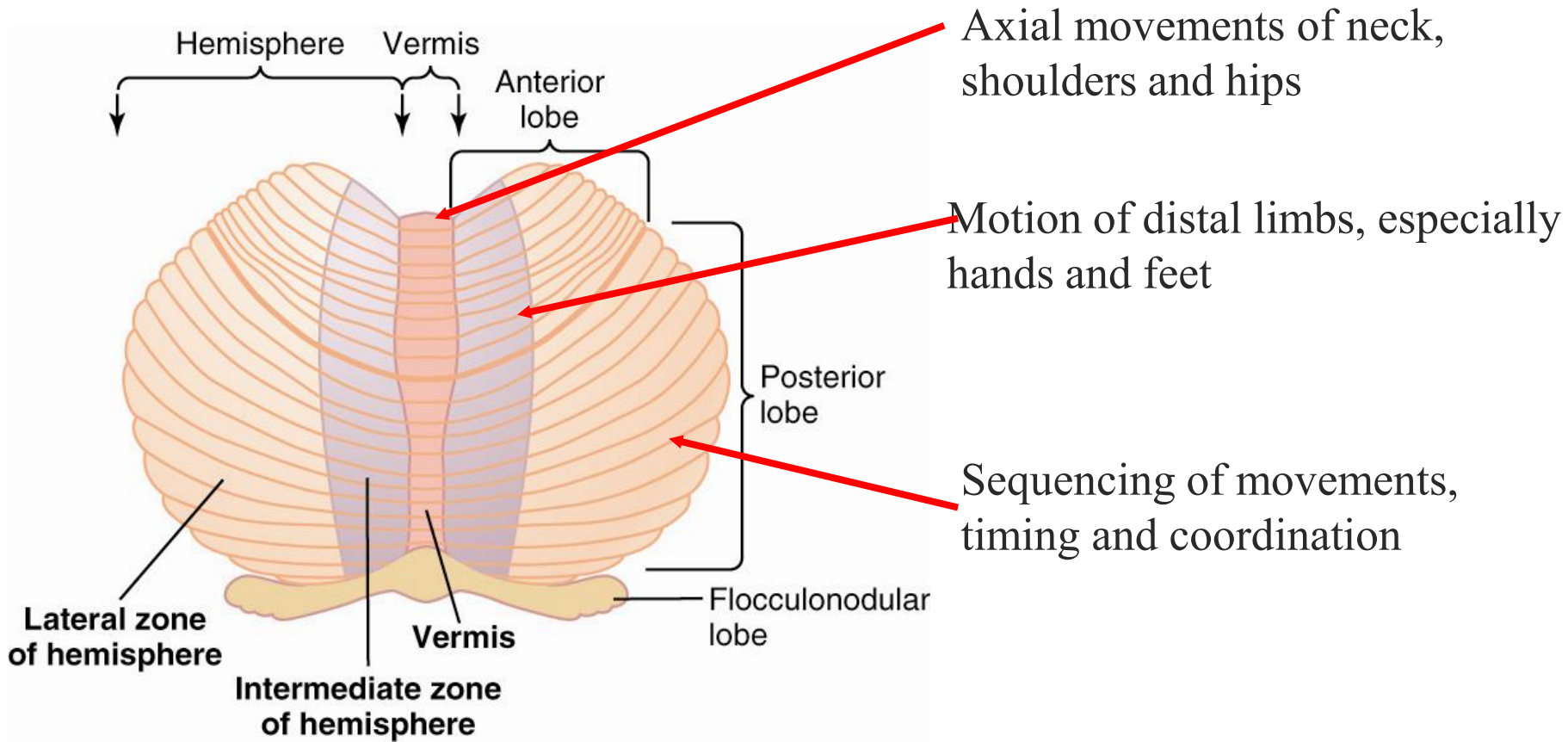

Cerebellar Topographical Representation

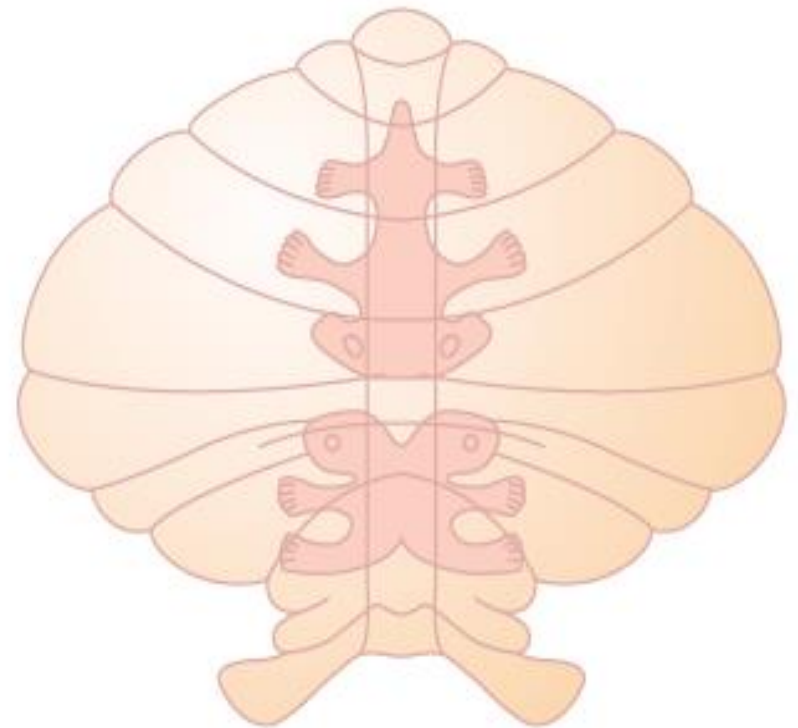
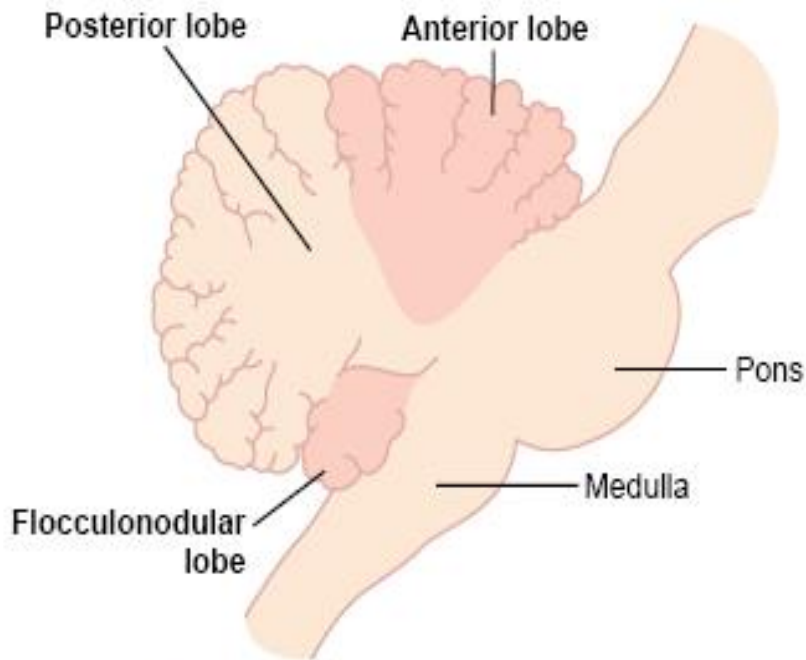

Afferent Pathways to the Cerebellum

From the brain

- *corticopontocerebellar* pathway from **motor** and **premotor** area, **somatosensory** cortex as well as some pontine nuclei which join this tract. Projects mostly to the **lateral hemispheric** areas.
- *olivocerebellar* tract, *vestibulocerebellar* tract, *reticulocerebellar* tract

- These pathways transmit information about intended motion.

Afferent Pathways to the Cerebellum

- from the periphery
 - *dorsal spinocerebellar tract* - transmits information mostly from **muscles spindle** but also from **Golgi tendon organs, large tactile, and joint receptors**. It is **uncrossed tract**
 - appraises the brain of the momentary status of muscle contraction, muscle tension and limb position and forces acting on the body surface
 - *ventral spinocerebellar tract* - signals from anterior horn, and interneurons (efference copy) the integrated signal from the final common pathway before it goes to the muscle. It is **bilateral tract**
 - transmits information on which signals have arrived at the cord



Sagittal plane

Corrective feedback

Motor areas of cerebral cortex

Thalamus

Cortex of cerebellum

Motor centers in brainstem

Pons

Pontine nuclei

Direct pathways

Indirect pathways

Signals to lower motor neurons

Sensory signals from proprioceptors in muscles and joints, vestibular apparatus, and eyes

3

4

1

2

Sagittal section through brain and spinal cord

Spinocerebellar tracts

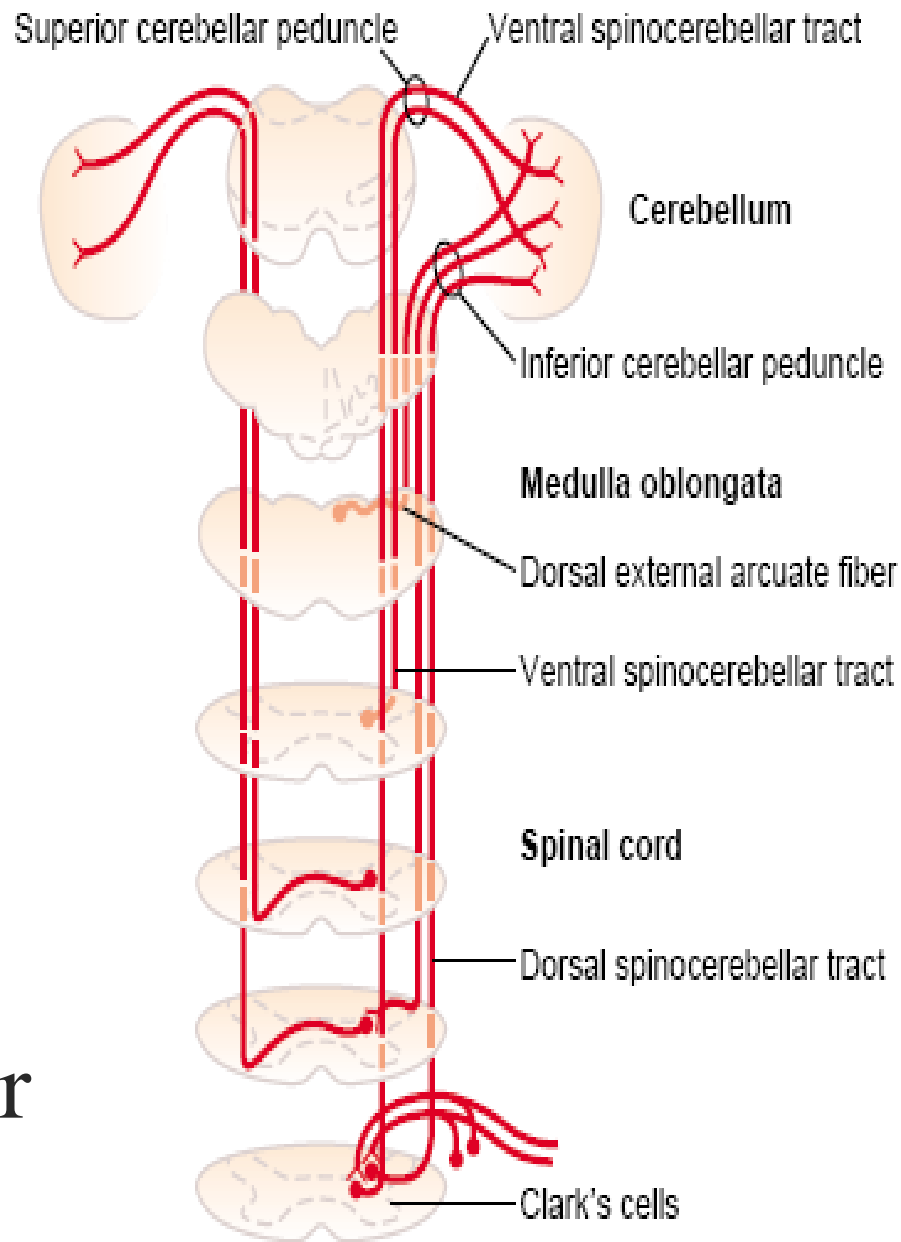

Efferent Pathways from the Cerebellum

- All efferents go out from deep cerebellar nuclei
- Vermis--fastigioreticular tract and from cerebellar cortex directly to lateral vestibular nuclei. (i.e. vestibular nuclei are functionally deep cerebellar nuclei)
 - equilibrium control
- Intermediate zone—Interpositorubral (Globos and Emboliform) fine voluntary movements of distal muscles
- Lateral hemisphere-- dentatothalamocortical tract
 - coordinates agonist and antagonist muscle contractions

Efferents of the cerebellum

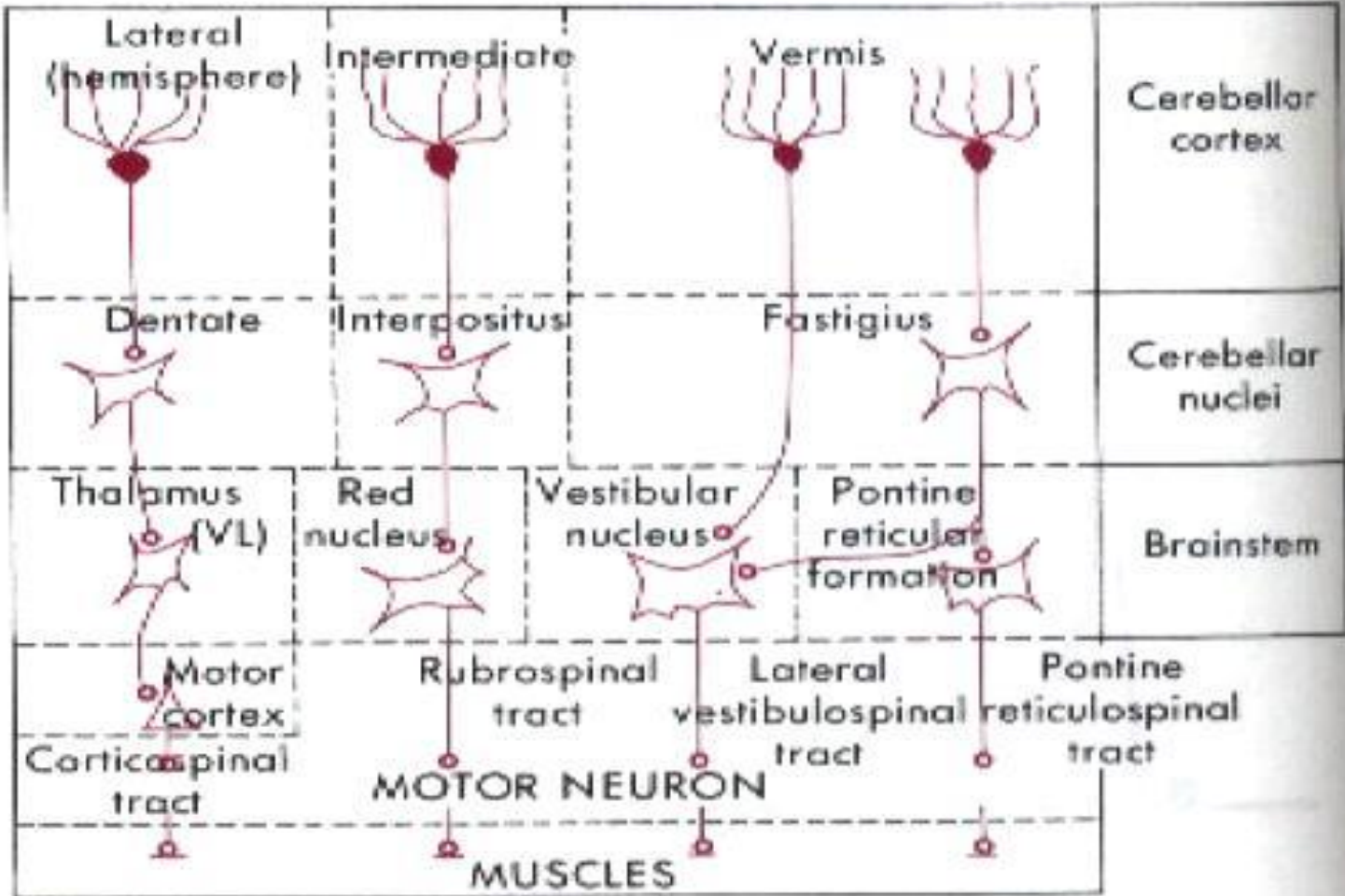

Neuronal Organization of the Cerebellar Cortex

- organized in three layers
 - molecular cell layer
 - Purkinje cell layer
 - granular cell layer
- output from the cerebellum comes from a deep nuclear cell layer located below these layers of cortex

Organization of the Cerebellum

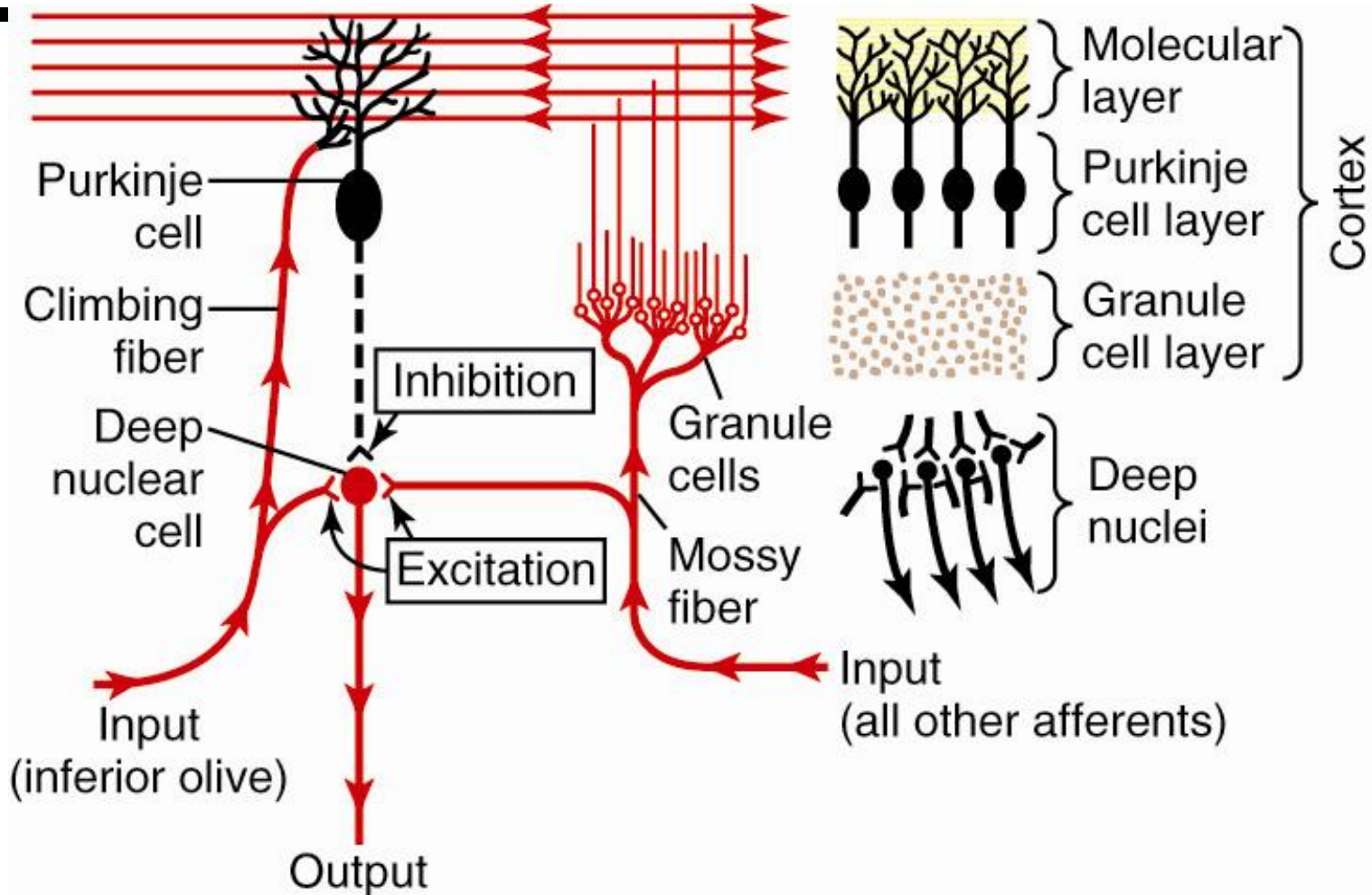

Neuronal Circuit of the Cerebellum

Deep nuclear cells receive excitatory and inhibitory inputs

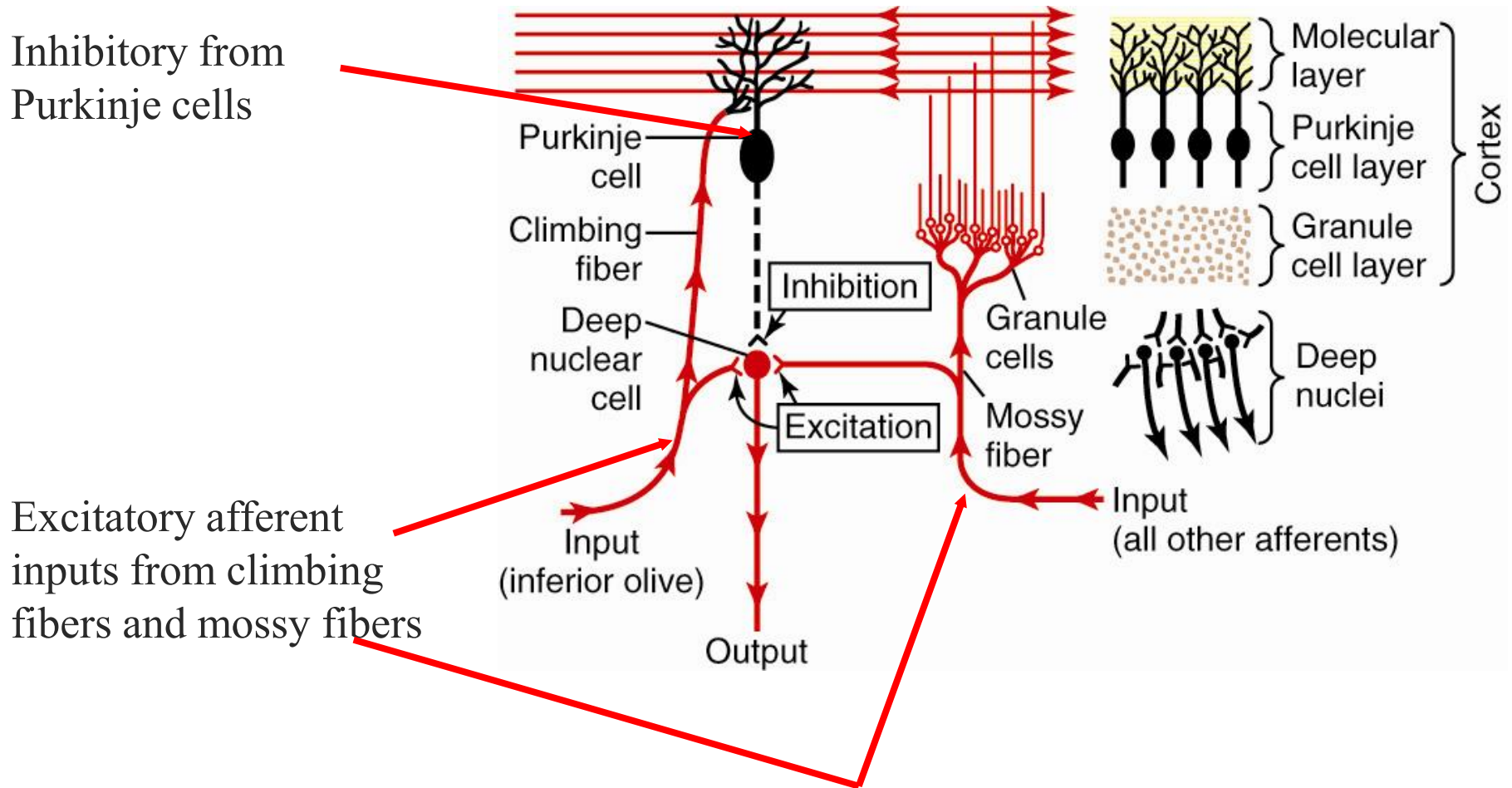

Neuronal Circuit of the Cerebellum

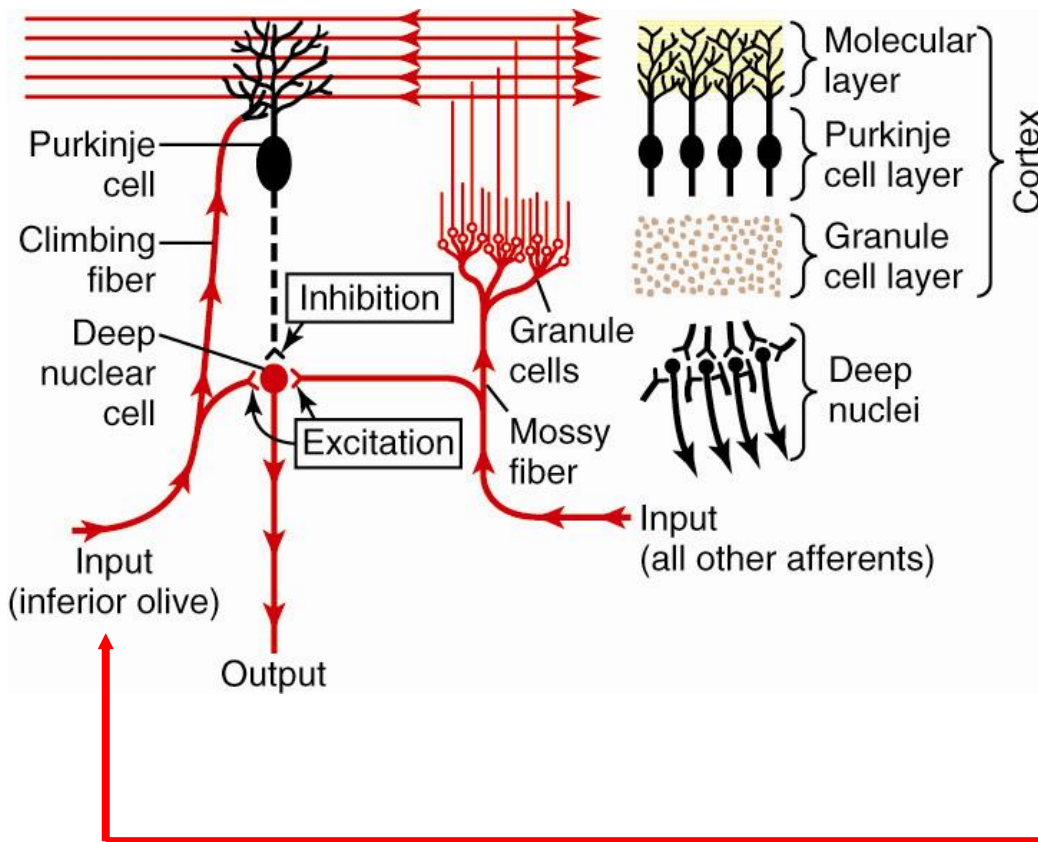

climbing fibers send branches to the deep nuclear cells before they make extensive connections with the dendrites of the Purkinje cell. Causes **complex spike** output from Purkinje cell.

Complex spike

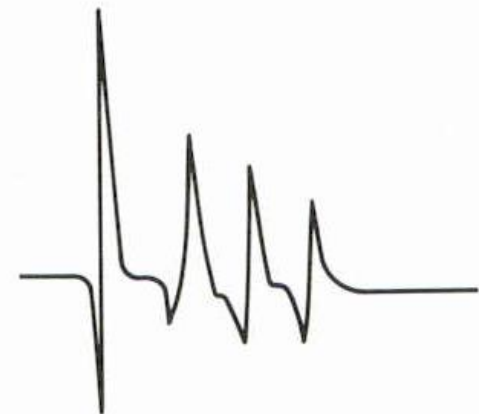

all **climbing fibers** originate from the inferior olive

Neuronal Circuit of the Cerebellum

mossy fibers relay all other afferent input into the cerebellum, also send branches to the deep nuclear cell

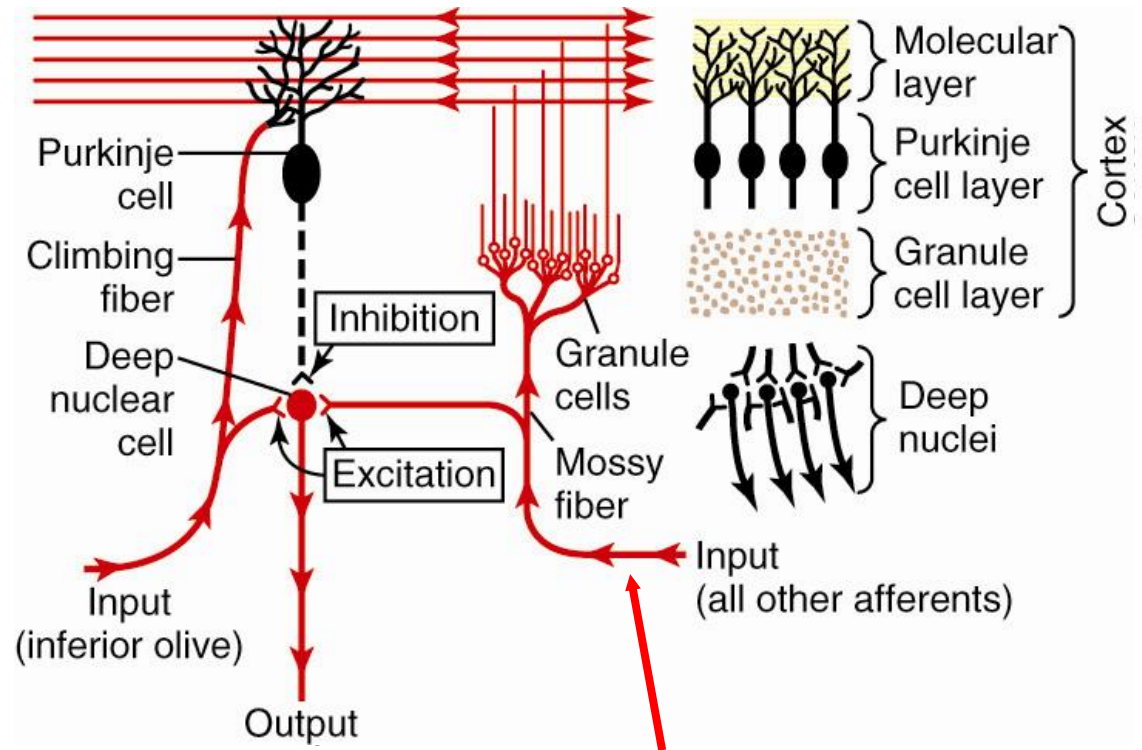

Simple spike

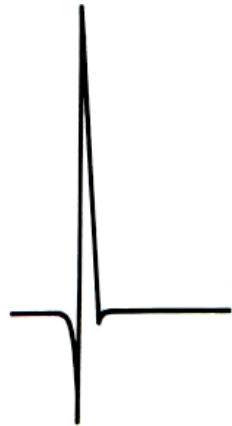

mossy fiber stimulation causes a simple spike output

mossy fibers terminate in the granular cell layer.

Neuronal Circuit of the Cerebellum

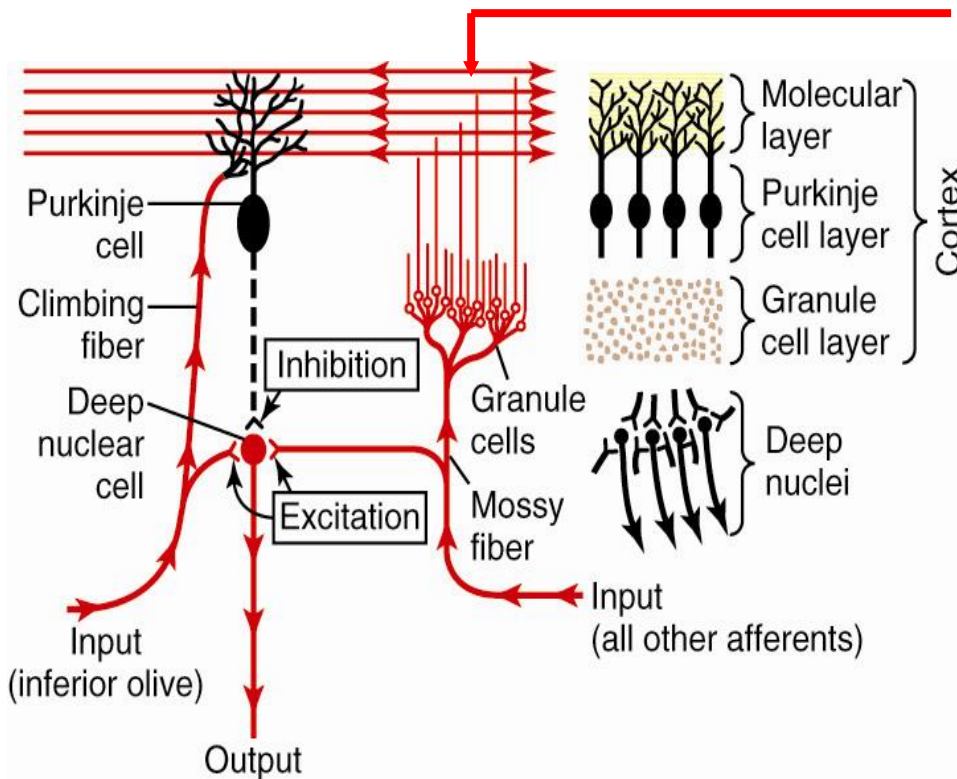

granular cells send axons to the molecular cell layer where they divide and go a few mm in opposite directions to become parallel fibers in the molecular layer

500 - 1000 granule cells for every Purkinje cell, anywhere from 80,000 to 200,000 parallel fibers synapse with each Purkinje cell

Deep Nuclear Cell Activity

Inhibited by Purkinje cell input

Stimulated by both climbing and mossy fiber input

Normally the balance is in favor of excitation

Deep nuclear cell at first receives an excitatory input from both the climbing fibers and mossy fibers.

This is followed by an inhibitory signal from the Purkinje cells

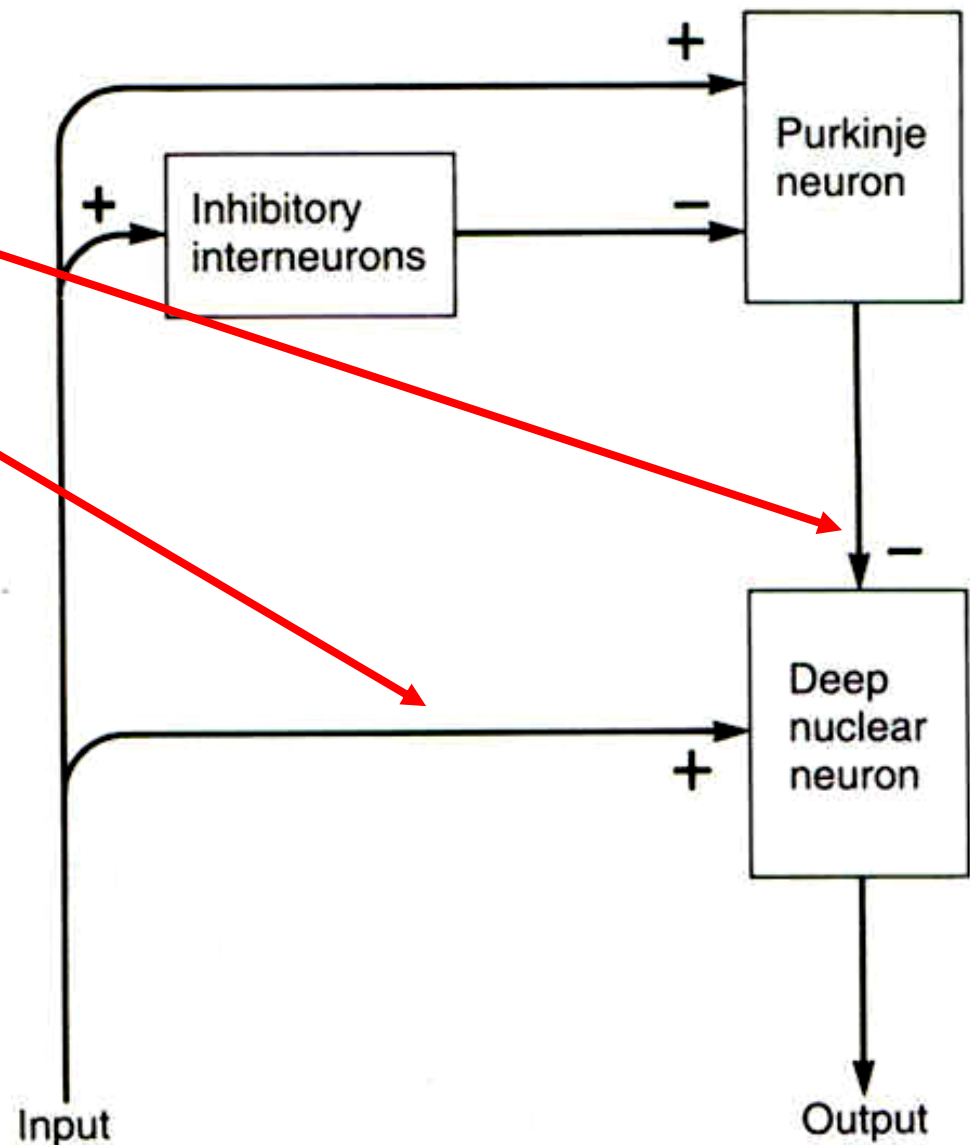

Deep Nuclear Cell Activity

- At beginning of motion there are excitatory signals sent into motor pathways by deep nuclear cells to enhance movement, followed by inhibitory signals milliseconds later.
 - Provides a damping function to stop movement from overshooting its mark
 - Resembles a delay-line type of electronic circuit for negative feedback

The Turn-On / Turn-Off Function

- cerebellum contributes to the rapid turn-on signals for agonist muscles and turn-off of antagonist muscles at beginning of a motion
- then it times the opposite sequence at the end of the intended motion
- direct motor pathway via corticospinal tract is enhanced by cerebellum by additional signals to the tract or by signals back to the cortex

The Turn-On / Turn-Off Function

- mossy fiber input also to Purkinje cells which activates them after a few millisecc., this results in an inhibitory signal to the deep nuclear cell
- this inhibits the agonist muscle which stops its activity

Purkinje Cells Function to Correct Motor Errors

- precise motor movement must be learned
- climbing fiber input adjusts the sensitivity of the Purkinje cells to stimulation by parallel fibers
- this changes the long-term sensitivity of the Purkinje cell to mossy fiber input (i.e., from muscle spindle, golgi tendon, proprioceptor)
- this adjusts the feedback control of muscle movement

Correction of Motor Errors

- **inferior olivary complex** receives input from:
 - corticospinal tract and motor centers of the brain stem
 - sensory information from muscles and surrounding tissue detailing the movement that actually occurs
- **inferior olivary complex** compares intent with actual function, if a mismatch occurs output to cerebellum through climbing fibers is altered to correct mismatch

Motion Control by the Cerebellum

- most cerebral cortical motions are **pendular**, therefore, there is **inertia and momentum**
- to move a limb accurately it must be **accelerated and decelerated** in the right sequence
- cerebellum **calculates momentum and inertia and initiates acceleration and braking activity**

Predictive and Timing Function of the Cerebellum

- motion is a series of discrete sequential movement
- the **planning and timing** of sequential movements is the function of the **lateral cerebellar hemisphere**
- this area communicates with **premotor** and **sensory cortex** and corresponding area of the **basal ganglia** where the plan originates
- the lateral hemisphere **receives the plan and times the sequential events to carry out the planned movement**

Cerebellar Voluntary Control

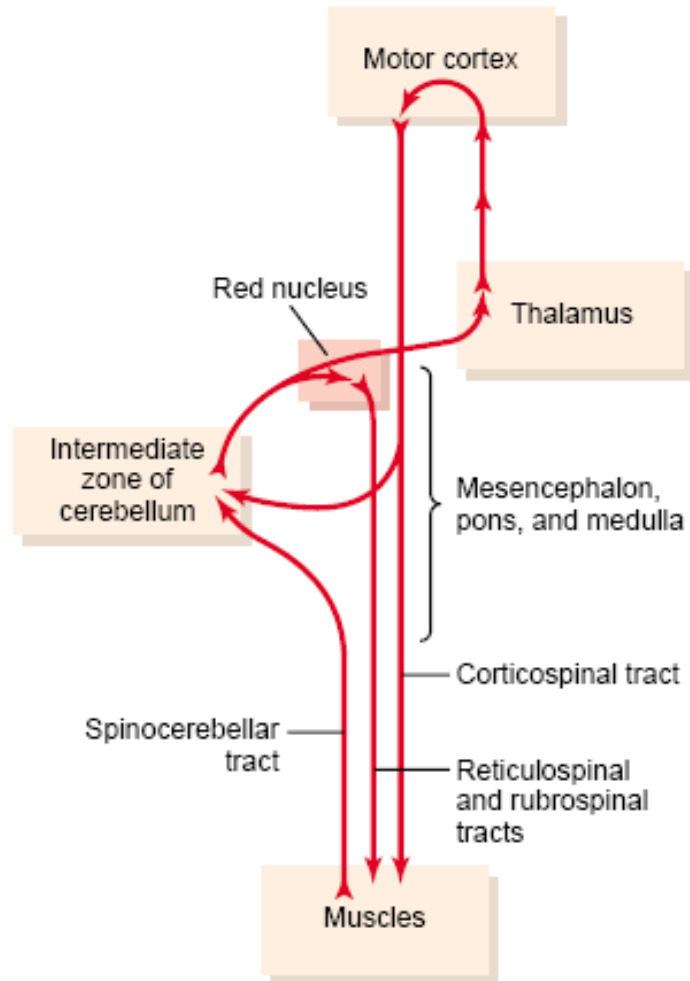

Integration of Motor Control

- Spinal cord level
 - preprogramming of patterns of movement of all muscles (i.e., withdrawal reflex, walking movements, etc.).
- Brainstem level
 - maintains equilibrium by adjusting axial tone
- Cortical level
 - issues commands to set into motion the patterns available in the spinal cord
 - controls the intensity and modifies the timing

Integration of Motor Control (cont'd)

- Cerebellum
 - function with all levels of control to adjust cord motor activity, equilibrium, and planning of motor activity
- Basal ganglia
 - functions to assist cortex in executing subconscious but learned patterns of movement, and to plan sequential patterns to accomplish a purposeful task

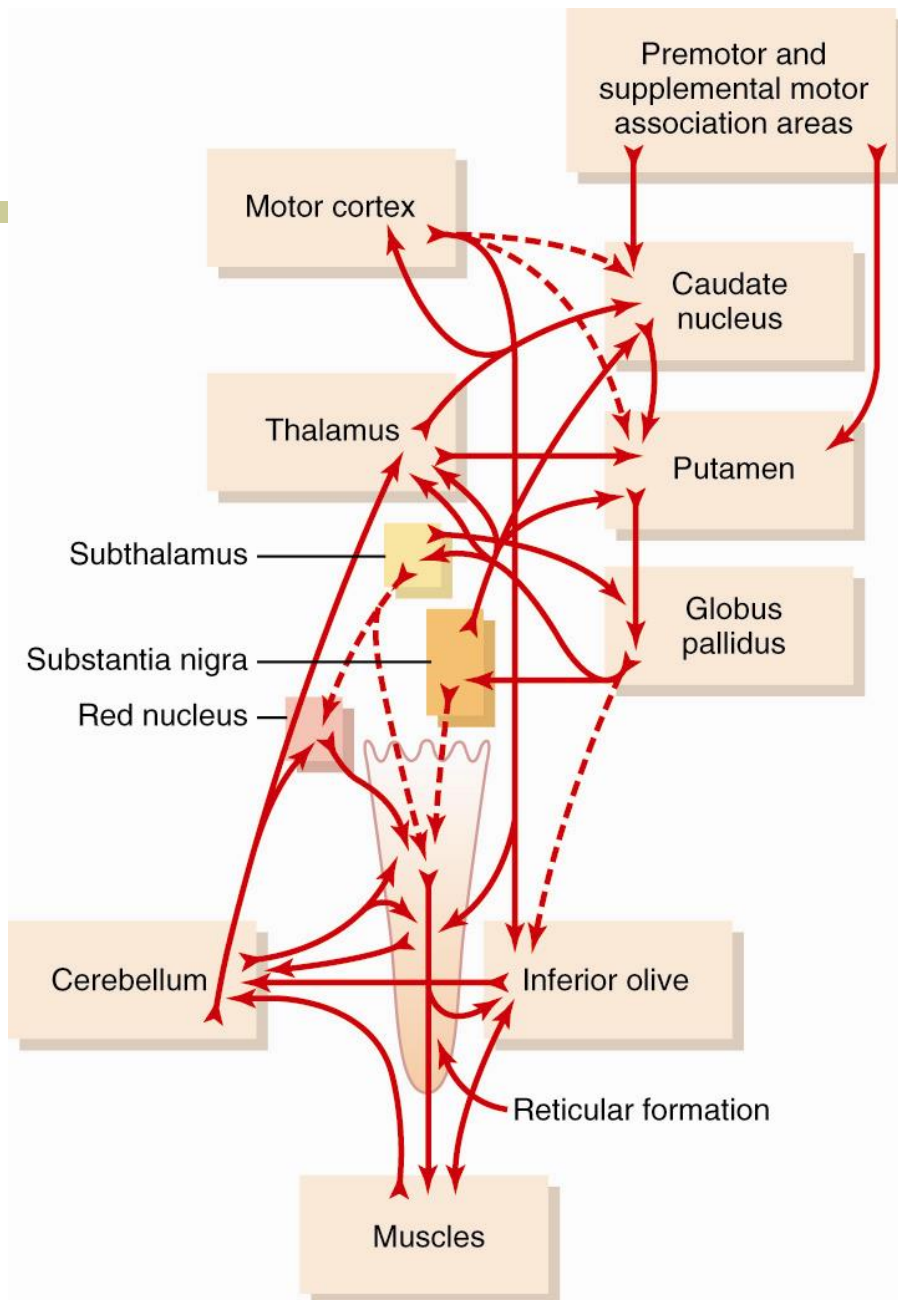

Overall scheme for integration of motor function

Clinical Abnormalities of the Cerebellum

- All signs of cerebellar diseases are ipsilateral since there is double crossing- from cortex to pons and back to cortex
- Ataxia and intention tremor
 - failure to predict motor movement, patients will overshoot intended target, **past pointing**.
 - Dysequilibrium- ataxic (staggering) gait (drunken gait)
- Dysdiadochokinesia (Adiadochokinesia)
 - failure of orderly progression of movement
- Dysarthria
 - failure of orderly progression in vocalization
- Cerebellar nystagmus
 - intention tremor of the eyes when trying to fix on object.



.com

T

H A N K

Y O U

U

U

2005

WILLS BRUNO

2005

THE WALK TO COMBAT DIABETES

2005

2005

JUNE 2005

Relay For Life
We're on Track
For a Cure